

**EXERCISE: 13.1****(PAGE NO: 244)**

1. 2 cubes each of volume 64 cm^3 are joined end to end. Find the surface area of the resulting cuboid.

Answer:

The diagram is given as:

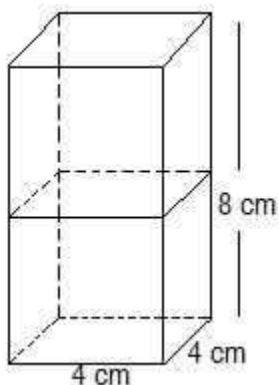

Given,

The Volume (V) of each cube is $= 64 \text{ cm}^3$

This implies that $a^3 = 64 \text{ cm}^3 \therefore$

$$a = 4 \text{ cm}$$

Now, the side of the cube $= a = 4 \text{ cm}$

Also, the length and breadth of the resulting cuboid will be 4 cm each, while its height will be 8 cm .

So, the surface area of the cuboid $= 2(lb+bh+lh)$

$$= 2(8 \times 4 + 4 \times 4 + 4 \times 8) \text{ cm}^2 =$$

$$2(32 + 16 + 32) \text{ cm}^2$$

$$= (2 \times 80) \text{ cm}^2 = 160 \text{ cm}^2$$

2. A vessel is in the form of a hollow hemisphere mounted by a hollow cylinder. The diameter of the hemisphere is 14 cm , and the total height of the vessel is 13 cm . Find the inner surface area of the vessel.

Answer:

The diagram is as follows:

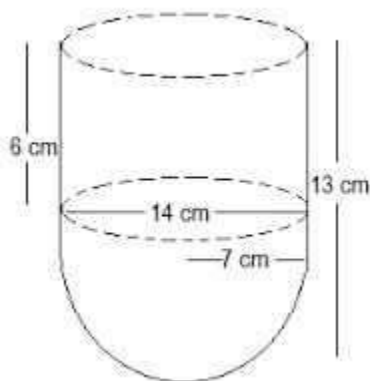

Now, the given parameters are:

The diameter of the hemisphere = $D = 14$ cm

The radius of the hemisphere = $r = 7$ cm

Also, the height of the cylinder = $h = (13 - 7) = 6$ cm

And the radius of the hollow hemisphere = 7 cm

Now, the inner surface area of the vessel = CSA of the cylindrical part + CSA of the hemispherical part

$$(2\pi rh + 2\pi r^2) \text{ cm}^2 = 2\pi r(h+r) \text{ cm}^2$$

$$2 \times (22/7) \times 7(6+7) \text{ cm}^2 = 572 \text{ cm}^2$$

3. A toy is in the form of a cone of radius 3.5 cm mounted on a hemisphere of the same radius. The total height of the toy is 15.5 cm. Find the total surface area of the toy.

Answer:

The diagram is as follows:

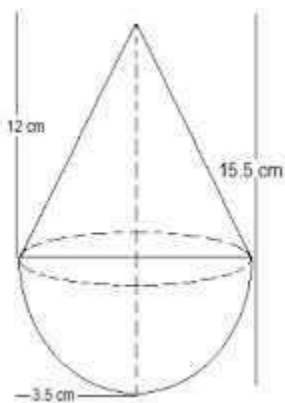

Given that the radius of the cone and the hemisphere (r) = 3.5 cm or $7/2$ cm

The total height of the toy is given as 15.5 cm.



So, the height of the cone (h) = $15.5 - 3.5 = 12$ cm

$$\text{Slant height of the cone (l)} = \sqrt{h^2 + r^2}$$

$$\Rightarrow l = \sqrt{12^2 + (3.5)^2}$$

$$\Rightarrow l = \sqrt{12^2 + (7/2)^2}$$

$$\Rightarrow l = \sqrt{144 + 49/4} = \sqrt{(576 + 49)/4} = \sqrt{625/4}$$

$$\Rightarrow l = 25/2$$

∴ The curved surface area of the cone = $\pi r l$

$$(22/7) \times (7/2) \times (25/2) = 275/2 \text{ cm}^2$$

Also, the curved surface area of the hemisphere = $2\pi r^2$

$$2 \times (22/7) \times (7/2)^2$$

$$= 77 \text{ cm}^2$$

Now, the Total surface area of the toy = CSA of the cone + CSA of the hemisphere

$$= (275/2) + 77 \text{ cm}^2$$

$$= (275 + 154)/2 \text{ cm}^2$$

$$= 429/2 \text{ cm}^2 = 214.5 \text{ cm}^2$$

So, the total surface area (TSA) of the toy is 214.5 cm^2

4. A cubical block of side 7 cm is surmounted by a hemisphere. What is the greatest diameter the hemisphere can have? Find the surface area of the solid.

Answer:

It is given that each side of the cube is 7 cm. So, the radius will be $7/2$ cm.

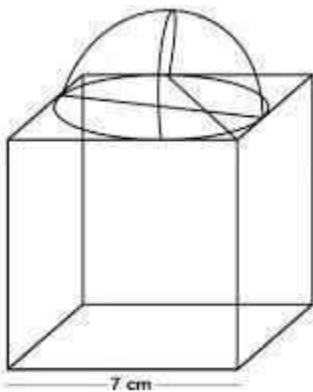



We know,

The total surface area of solid (TSA) = surface area of the cubical block + CSA of the hemisphere – Area of the base of the hemisphere

$$\begin{aligned}\therefore \text{TSA of solid} &= 6 \times (\text{side})^2 + 2\pi r^2 - \pi r^2 \\ &= 6 \times (\text{side})^2 + \pi r^2 \\ &= 6 \times (7)^2 + (22/7) \times (7/2) \times (7/2) \\ &= (6 \times 49) + (77/2) \\ &= 294 + 38.5 = 332.5 \text{ cm}^2\end{aligned}$$

So, the surface area of the solid is 332.5 cm²

5. A hemispherical depression is cut out from one face of a cubical wooden block such that the diameter l of the hemisphere is equal to the edge of the cube. Determine the surface area of the remaining solid.

Answer:

The diagram is as follows:

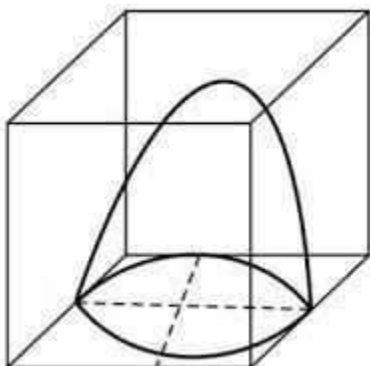

Now, the diameter of the hemisphere = Edge of the cube = l

So, the radius of the hemisphere = $l/2$

\therefore The total surface area of solid = surface area of cube + CSA of the hemisphere – Area of the base of the hemisphere

$$\begin{aligned}\text{The surface area of the remaining solid} &= 6(\text{edge})^2 + 2\pi r^2 - \pi r^2 \\ &= 6l^2 + \pi r^2 \\ &= 6l^2 + \pi(l/2)^2 \\ &= 6l^2 + \pi l^2/4 \\ &= l^2/4(24 + \pi) \text{ sq. units}\end{aligned}$$



6. A medicine capsule is in the shape of a cylinder with two hemispheres stuck to each of its ends. The length of the entire capsule is 14 mm, and the diameter of the capsule is 5 mm. Find its surface area.

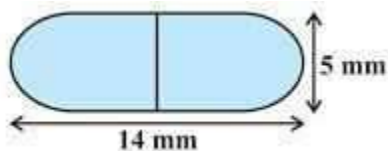

Answer:

Two hemispheres and one cylinder are shown in the figure given below.

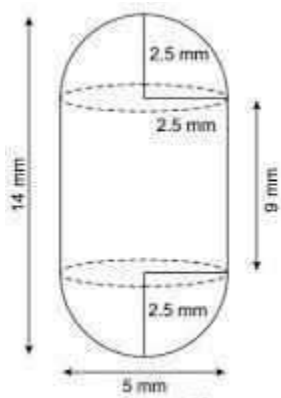

Here, the diameter of the capsule = 5 mm

$$\therefore \text{Radius} = 5/2 = 2.5 \text{ mm}$$

Now, the length of the capsule = 14 mm

$$\text{So, the length of the cylinder} = 14 - (2.5 + 2.5) = 9 \text{ mm}$$

$$\begin{aligned} \therefore \text{The surface area of a hemisphere} &= 2\pi r^2 = 2 \times (22/7) \times 2.5 \times 2.5 \\ &= 275/7 \text{ mm}^2 \end{aligned}$$

Now, the surface area of the cylinder = $2\pi rh$

$$= 2 \times (22/7) \times 2.5 \times 9$$

$$(22/7) \times 45 = 990/7 \text{ mm}^2$$

Thus, the required surface area of the medicine capsule will be

$$= 2 \times \text{surface area of hemisphere} + \text{surface area of the cylinder}$$

$$= (2 \times 275/7) + 990/7$$

$$= (550/7) + (990/7) = 1540/7 = 220 \text{ mm}^2$$



7. A tent is in the shape of a cylinder surmounted by a conical top. If the height and diameter of the cylindrical part are 2.1 m and 4 m, respectively, and the slant height of the top is 2.8 m, find the area of the canvas used for making the tent. Also, find the cost of the canvas of the tent at the rate of Rs 500 per m^2 . (Note that the base of the tent will not be covered with canvas.)

Answer:

It is known that a tent is a combination of a cylinder and a cone.

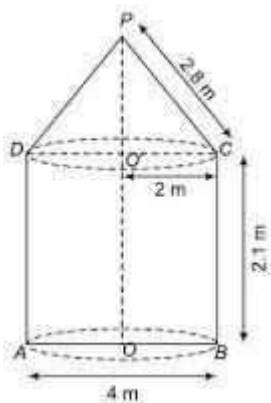

From the question, we know that

Diameter = 4 m

The slant height of the cone (l) = 2.8 m

Radius of the cone (r) = Radius of cylinder = $4/2 = 2$ m

Height of the cylinder (h) = 2.1 m

So, the required surface area of the tent = surface area of the cone + surface area of the cylinder

$$= \pi r l + 2\pi r h$$

$$= \pi r (l + 2h)$$

$$= (22/7) \times 2 (2.8 + 2 \times 2.1)$$

$$= (44/7) (2.8 + 4.2)$$

$$= (44/7) \times 7 = 44 \text{ m}^2$$

\therefore The cost of the canvas of the tent at the rate of ₹500 per m^2 will be

$$= \text{Surface area} \times \text{cost per m}^2$$

$$44 \times 500 = ₹22000$$

So, Rs. 22000 will be the total cost of the canvas.



8. From a solid cylinder whose height is 2.4 cm and diameter is 1.4 cm, a conical cavity of the same height and same diameter is hollowed out. Find the total surface area of the remaining solid to the nearest cm^2 .

Answer:

The diagram for the question is as follows:

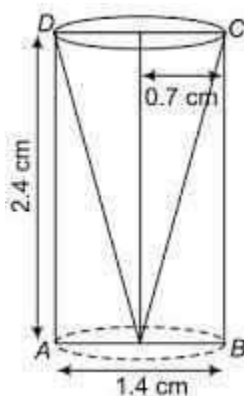

From the question, we know the following:

The diameter of the cylinder = diameter of conical cavity = 1.4 cm

So, the radius of the cylinder = radius of the conical cavity = $1.4/2 = 0.7$ Also,

the height of the cylinder = height of the conical cavity = 2.4 cm

$$\begin{aligned}\therefore \text{Slant height of the conical cavity } (l) &= \sqrt{h^2 + r^2} \\ &= \sqrt{(2.4)^2 + (0.7)^2} \\ &= \sqrt{5.76 + 0.49} = \sqrt{6.25} \\ &= 2.5 \text{ cm}\end{aligned}$$

Now, the TSA of the remaining solid = surface area of conical cavity + TSA of the cylinder

$$= \pi r l + (2\pi r h + \pi r^2)$$

$$= \pi r (l + 2h + r)$$

$$= (22/7) \times 0.7 (2.5 + 4.8 + 0.7)$$

$$= 2.2 \times 8 = 17.6 \text{ cm}^2$$

So, the total surface area of the remaining solid is 17.6 cm^2

**EXERCISE: 13.2****(PAGE NO: 247)**

1. A solid is in the shape of a cone standing on a hemisphere, with both their radii being equal to 1 cm and the height of the cone being equal to its radius. Find the volume of the solid in terms of π .

Solution:

Here $r = 1$ cm and $h = 1$ cm.

The diagram is as follows.

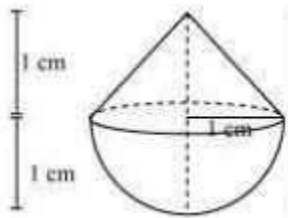

Now, Volume of solid = Volume of conical part + Volume of hemispherical part

We know the volume of cone = $\frac{1}{3} \pi r^2 h$

And,

The volume of the hemisphere = $\frac{2}{3} \pi r^3$

So, the volume of the solid will be

$$= \frac{1}{3} \pi (1)^2 [1 + 2(1)] \text{ cm}^3 = \frac{1}{3} \pi \times 1 \times [3] \text{ cm}^3$$

$$= \pi \text{ cm}^3$$

2. Rachel, an engineering student, was asked to make a model shaped like a cylinder with two cones attached at its two ends by using a thin aluminium sheet. The diameter of the model is 3 cm, and its length is 12 cm. If each cone has a height of 2 cm, find the volume of air contained in the model that Rachel made. (Assume the outer and inner dimensions of the model are nearly the same.)

Solution:

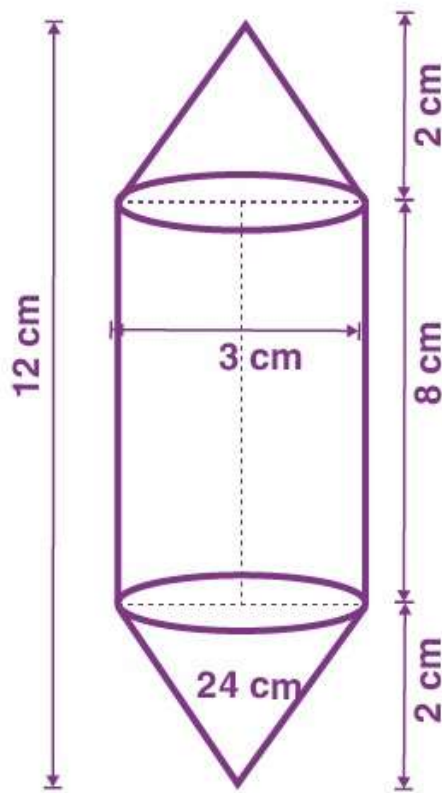

Given,

Height of cylinder = $12 - 4 = 8$ cm

Radius = 1.5 cm

Height of cone = 2 cm

Now, the total volume of the air contained will be = Volume of cylinder + $2 \times$ (Volume of the cone)

$$\therefore \text{Total volume} = \pi r^2 h + [2 \times (\frac{1}{3} \pi r^2 h)]$$

$$= 18 \pi + 2(1.5 \pi) =$$

$$66 \text{ cm}^3.$$

3. A gulab jamun contains sugar syrup up to about 30% of its volume. Find approximately how much syrup would be found in 45 gulab jamuns, each shaped like a cylinder with two hemispherical ends with a length of 5 cm and a diameter of 2.8 cm (see figure).

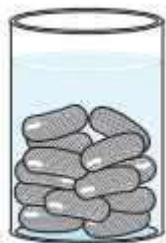
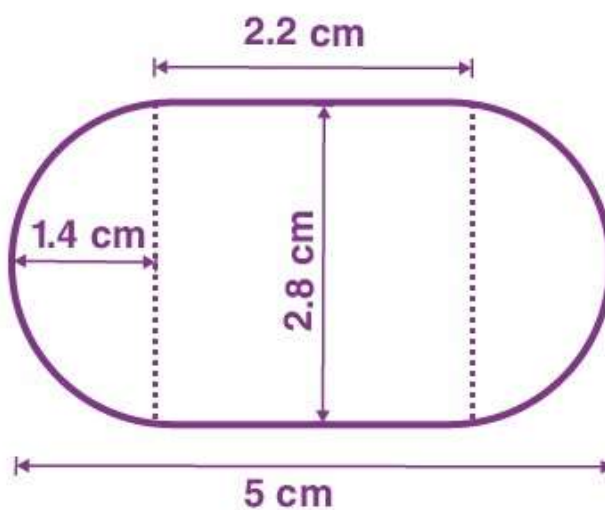

Fig. 13.15

Solution:



It is known that the gulab jamuns are similar to a cylinder with two hemispherical ends.

So, the total height of a gulab jamun = 5 cm.

Diameter = 2.8 cm

So, radius = 1.4 cm

∴ The height of the cylindrical part = 5 cm – (1.4 + 1.4) cm

= 2.2 cm

Now, the total volume of one gulab jamun = Volume of cylinder + Volume of two hemispheres

$$= \pi r^2 h + (4/3)\pi r^3$$

$$= 4.312\pi + (10.976/3)\pi$$

$$= 25.05 \text{ cm}^3$$



We know that the volume of sugar syrup = 30% of the total volume

So, the volume of sugar syrup in 45 gulab jamuns = $45 \times 30\%$ (25.05 cm^3)

$$= 45 \times 7.515 = 338.184 \text{ cm}^3$$

4. A pen stand made of wood is in the shape of a cuboid with four conical depressions to hold pens. The dimensions of the cuboid are 15 cm by 10 cm by 3.5 cm. The radius of each of the depressions is 0.5 cm, and the depth is 1.4 cm. Find the volume of wood in the entire stand (see Fig.).

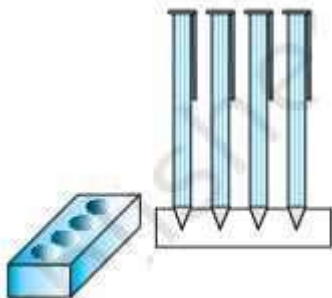

Fig. 13.16

Solution:

The volume of the cuboid = length \times width \times height

We know the cuboid's dimensions as $15 \text{ cm} \times 10 \text{ cm} \times 3.5 \text{ cm}$

So, the volume of the cuboid = $15 \times 10 \times 3.5 = 525 \text{ cm}^3$

Here, depressions are like cones, and we know,

Volume of cone = $(\frac{1}{3})\pi r^2 h$

Given, radius (r) = 0.5 cm and depth (h) = 1.4 cm

\therefore Volume of 4 cones = $4 \times (\frac{1}{3})\pi r^2 h$

$$= 1.46 \text{ cm}^3$$

Now, the volume of wood = Volume of the cuboid – 4 \times volume of the cone

$$= 525 - 1.46 = 523.54 \text{ cm}^3$$

5. A vessel is in the form of an inverted cone. Its height is 8 cm and the radius of its top, which is open, is 5 cm. It is filled with water up to the brim. When lead shots, each of which is a sphere of radius 0.5 cm, are dropped into the vessel, one-fourth of the water flows out. Find the number of lead shots dropped in the vessel.

Solution:

For the cone,



Radius = 5 cm,

Height = 8 cm

Also,

Radius of sphere = 0.5 cm

The diagram will be like

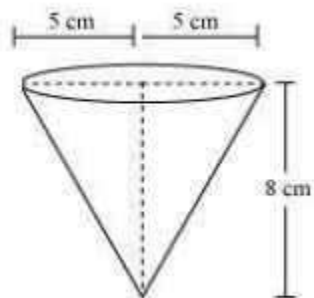

It is known that,

The volume of cone = volume of water in the cone

$$= \frac{1}{3}\pi r^2 h = (200/3)\pi \text{ cm}^3$$

Now,

$$\text{Total volume of water overflow} = (1/4) \times (200/3) \pi = (50/3)\pi$$

The volume of lead shot

$$= (4/3)\pi r^3$$

$$= (1/6) \pi$$

Now,

The number of lead shots = Total volume of water overflow / Volume of lead shot

$$= (50/3)\pi / (1/6)\pi$$

$$= (50/3) \times 6 = 100$$

6. A solid iron pole consists of a cylinder of height 220 cm and base diameter 24 cm, which is surmounted by another cylinder of height 60 cm and radius 8 cm. Find the mass of the pole, given that 1 cm³ of iron has approximately 8 g mass.

Solution:

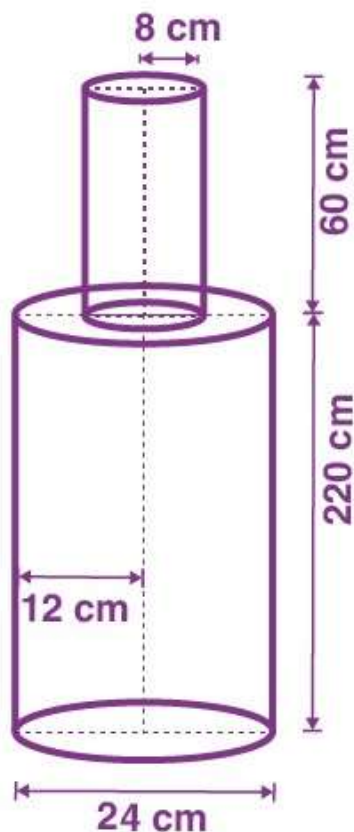

Given the height of the big cylinder (H) = 220 cm

The radius of the base (R) = $24/2 = 12$ cm

So, the volume of the big cylinder = $\pi R^2 H$

$$= \pi(12)^2 \times 220 \text{ cm}^3$$

$$= 99565.8 \text{ cm}^3$$

Now, the height of the smaller cylinder (h) = 60 cm

The radius of the base (r) = 8 cm

So, the volume of the smaller cylinder = $\pi r^2 h$

$$= \pi(8)^2 \times 60 \text{ cm}^3$$

$$= 12068.5 \text{ cm}^3$$

∴ The volume of iron = Volume of the big cylinder + Volume of the small cylinder

$$= 99565.8 + 12068.5$$



$$= 111634.5 \text{ cm}^3$$

We know,

$$\text{Mass} = \text{Density} \times \text{volume}$$

$$\text{So, the mass of the pole} = 8 \times 111634.5$$

$$= 893 \text{ Kg (approx.)}$$

7. A solid consisting of a right circular cone of height 120 cm and radius 60 cm standing on a hemisphere of radius 60 cm is placed upright in a right circular cylinder full of water such that it touches the bottom. Find the volume of water left in the cylinder if the radius of the cylinder is 60 cm and its height is 180 cm.

Solution:

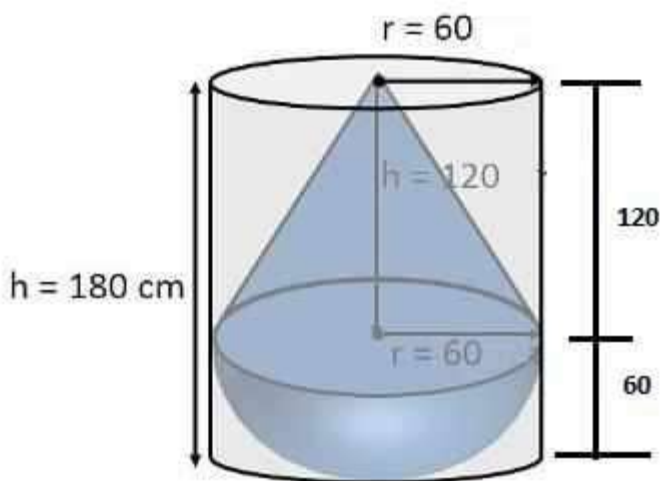

Here, the volume of water left will be = Volume of the cylinder – Volume of solid Given,

Radius of cone = 60 cm,

Height of cone = 120 cm

Radius of cylinder = 60 cm

Height of cylinder = 180 cm

Radius of hemisphere = 60 cm

Now,

The total volume of solid = Volume of Cone + Volume of the hemisphere

$$\text{Volume of cone} = \frac{1}{3}\pi r^2 h = \frac{1}{3} \times \pi \times 60^2 \times 120 \text{ cm}^3 = 144 \times 10^3 \pi \text{ cm}^3$$



$$\text{Volume of hemisphere} = \left(\frac{2}{3}\right) \times \pi \times 60^3 \text{ cm}^3 = 144 \times 10^3 \pi \text{ cm}^3$$

$$\text{So, total volume of solid} = 144 \times 10^3 \pi \text{ cm}^3 + 144 \times 10^3 \pi \text{ cm}^3 = 288 \times 10^3 \pi \text{ cm}^3$$

$$\text{Volume of cylinder} = \pi \times 60^2 \times 180 = 648000 = 648 \times 10^3 \pi \text{ cm}^3$$

Now, the volume of water left will be = Volume of the cylinder – Volume of solid

$$= (648 - 288) \times 10^3 \times \pi = 1.131 \text{ m}^3$$

8. A spherical glass vessel has a cylindrical neck 8 cm long and 2 cm in diameter; the diameter of the spherical part is 8.5 cm. By measuring the amount of water it holds, a child finds its volume to be 345 cm³. Check whether she is correct, taking the above as the inside measurements and $\pi = 3.14$.

Solution:

Given,

For the cylinder part, Height (h) = 8 cm and Radius (R) = (2/2) cm = 1 cm For

the spherical part, Radius (r) = (8.5/2) = 4.25 cm

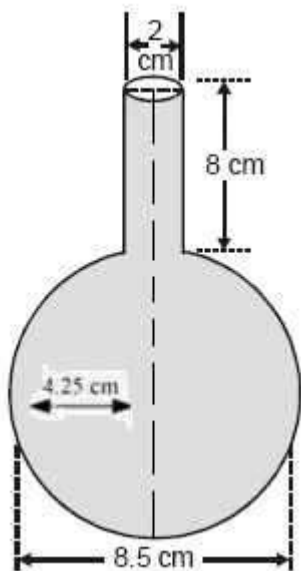

Now, volume of this vessel = Volume of cylinder + Volume of sphere

$$= \pi \times (1)^2 \times 8 + \left(\frac{4}{3}\right) \pi (4.25)^3$$

$$= 346.51 \text{ cm}^3$$

Hence, the child's calculation is not correct.

**EXERCISE: 13.3****(PAGE NO: 251)**

1. A metallic sphere of radius 4.2 cm is melted and recast into the shape of a cylinder of radius 6 cm. Find the height of the cylinder.

Solution:

It is given that radius of the sphere (R) = 4.2 cm

Also, the radius of the cylinder (r) = 6 cm

Now, let the height of the cylinder = h

It is given that the sphere is melted into a cylinder. So,

the volume of the sphere = Volume of the cylinder

$$\therefore (4/3) \times \pi \times R^3 = \pi \times r^2 \times h.$$

$$h = 2.74 \text{ cm}$$

2. Metallic spheres of radii 6 cm, 8 cm and 10 cm, respectively, are melted to form a single solid sphere. Find the radius of the resulting sphere.

Solution:

For Sphere 1:

Radius (r_1) = 6 cm

$$\therefore \text{Volume } (V_1) = (4/3) \times \pi \times r_1^3$$

For Sphere 2:

Radius (r_2) = 8 cm

$$\therefore \text{Volume } (V_2) = (4/3) \times \pi \times r_2^3$$

For Sphere 3:

Radius (r_3) = 10 cm

$$\therefore \text{Volume } (V_3) = (4/3) \times \pi \times r_3^3$$

Also, let the radius of the resulting sphere be “r”

Now,

The volume of the resulting sphere = $V_1 + V_2 + V_3$

$$(4/3) \times \pi \times r^3 = (4/3) \times \pi \times r_1^3 + (4/3) \times \pi \times r_2^3 + (4/3) \times \pi \times r_3^3$$



$$r^3 = 6^3 + 8^3 + 10^3$$

$$r^3 = 1728 \quad r =$$

12 cm

3. A 20 m deep well with a diameter of 7 m is dug, and the earth from digging is evenly spread out to form a platform 22 m by 14 m. Find the height of the platform.

Solution:

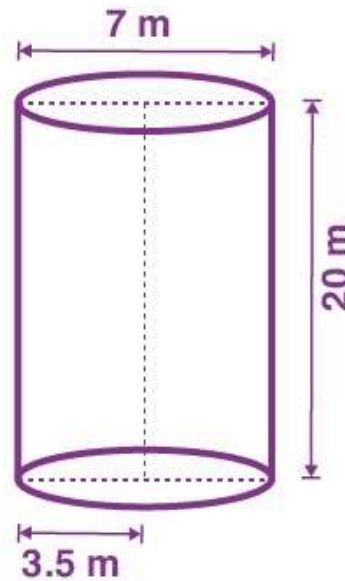

It is given that the shape of the well is the shape of a cylinder with a diameter of 7 m

So, radius = $7/2$ m

Also, Depth (h) = 20 m

The volume of the earth dug out will be equal to the volume of the cylinder

Let the height of the platform = H

The volume of soil from the well (cylinder) = Volume of soil used to make such a platform $\pi \times r^2 \times h$

= Area of platform \times Height of the platform

We know that the dimension of the platform is = 22×14

So, the Area of the platform = $22 \times 14 \text{ m}^2 \therefore$

$$\pi \times r^2 \times h = 22 \times 14 \times H$$



$$\Rightarrow H = 2.5 \text{ m}$$

4. A well of diameter 3 m is dug 14 m deep. The earth taken out of it has been spread evenly all around it in the shape of a circular ring of width 4 m to form an embankment. Find the height of the embankment.

Solution:

The shape of the well will be cylindrical, as given below.

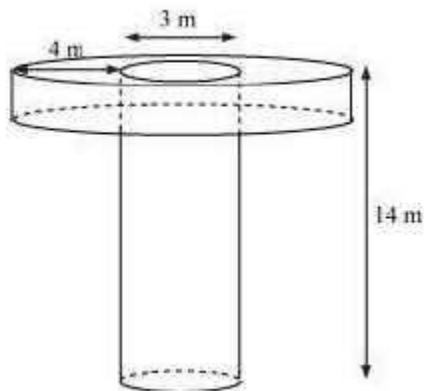

Given, depth (h_1) of well = 14 m

Diameter of the circular end of the well = 3 m

So, Radius (r_1) = $3/2$ m

Width of the embankment = 4 m

From the figure, it can be said that the embankment will be a cylinder having an outer radius (r_2) as $4 + (3/2) = 11/2$ m and an inner radius (r_1) as $3/2$ m

Now, let the height of the embankment be h_2

\therefore The volume of soil dug from the well = Volume of earth used to form the embankment $\pi \times r_1^2 \times h_1$

$$= \pi \times (r_2^2 - r_1^2) \times h_2$$

Solving this, we get,

The height of the embankment (h_2) is 1.125 m.

5. A container shaped like a right circular cylinder having a diameter of 12 cm and a height of 15 cm is full of ice cream. The ice cream is to be filled into cones of height 12 cm and diameter 6 cm, having a hemispherical shape on the top. Find the number of such cones which can be filled with ice cream.

Solution:

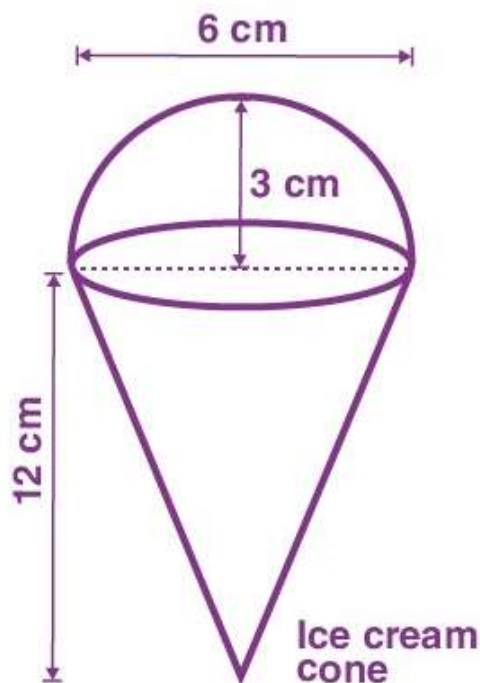
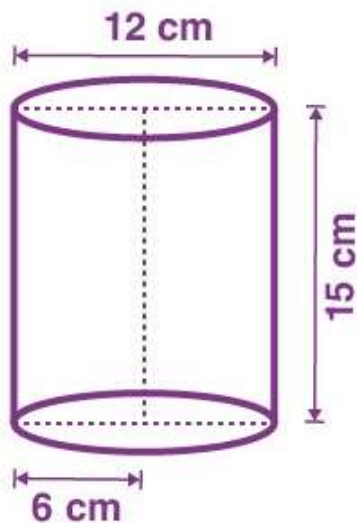

The number of cones will be = Volume of cylinder/Volume of ice cream cone

For the cylinder part,

$$\text{Radius} = 12/2 = 6 \text{ cm}$$

$$\text{Height} = 15 \text{ cm}$$

$$\therefore \text{Volume of cylinder} = \pi \times r^2 \times h = 540\pi$$

For the ice cone part,

$$\text{Radius of conical part} = 6/2 = 3 \text{ cm}$$

$$\text{Height} = 12 \text{ cm}$$

$$\text{Radius of hemispherical part} = 6/2 = 3 \text{ cm}$$

Now,

The volume of the ice cream cone = Volume of the conical part + Volume of the hemispherical part

$$= \left(\frac{1}{3}\right) \times \pi \times r^2 \times h + \left(\frac{2}{3}\right) \times \pi \times r^3$$

$$= 36\pi + 18\pi$$



$$= 54\pi$$

$$\therefore \text{Number of cones} = (540\pi/54\pi)$$

$$= 10$$

6. How many silver coins, 1.75 cm in diameter and of thickness 2 mm, must be melted to form a cuboid of dimensions 5.5 cm × 10 cm × 3.5 cm?

Solution:



It is known that the coins are cylindrical in shape.

So, height (h_1) of the cylinder = 2 mm = 0.2 cm

Radius (r) of circular end of coins = $1.75/2 = 0.875$ cm

Now, the number of coins to be melted to form the required cuboids be “ n ”

So, Volume of n coins = Volume of cuboids $n \times \pi \times r^2 \times h_1 = l \times b \times h$

$$n \times \pi \times (0.875)^2 \times 0.2 = 5.5 \times 10 \times 3.5$$

$$\text{Or, } n = 400$$

7. A cylindrical bucket, 32 cm high and with a radius of a base of 18 cm, is filled with sand. This bucket is emptied on the ground, and a conical heap of sand is formed. If the height of the conical heap is 24 cm, find the radius and slant height of the heap.

Solution:

The diagram will be as-

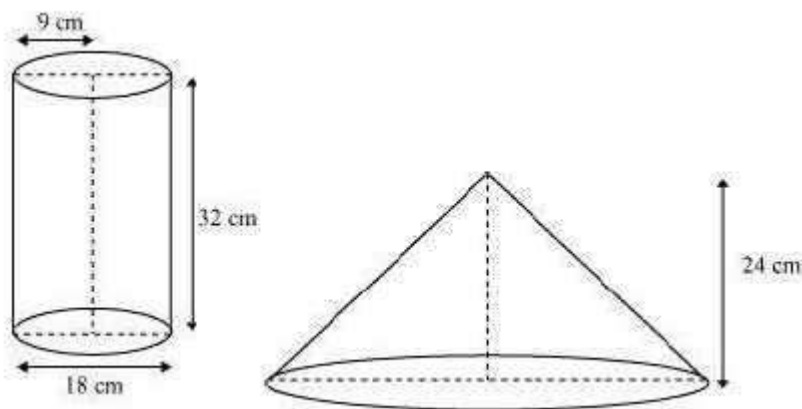

Given,

Height (h_1) of cylindrical part of the bucket = 32 cm

Radius (r_1) of circular end of the bucket = 18 cm

Height of the conical heap (h_2) = 24 cm

Now, let " r_2 " be the radius of the circular end of the conical heap.

We know that volume of the sand in the cylindrical bucket will be equal to the volume of sand in the conical heap.

∴ The volume of sand in the cylindrical bucket = Volume of sand in the conical heap

$$\pi \times r_1^2 \times h_1 = \left(\frac{1}{3}\right) \times \pi \times r_2^2 \times h_2 \quad \pi \times 18^2 \times 32 = \left(\frac{1}{3}\right) \times \pi \times r_2^2 \times 24$$

$$\text{Or, } r_2 = 36 \text{ cm}$$

And,

$$\text{Slant height (l)} = \sqrt{(36^2 + 24^2)} = 12\sqrt{13} \text{ cm.}$$

8. Water in a canal, 6 m wide and 1.5 m deep, flows at a speed of 10 km/h. How much area will it irrigate in 30 minutes if 8 cm of standing water is needed?

Solution:

It is given that the canal is the shape of a cuboid with dimensions as:

Breadth (b) = 6 m and Height (h) = 1.5 m

It is also given that

The speed of canal = 10 km/hr

Length of canal covered in 1 hour = 10 km

Length of canal covered in 60 minutes = 10 km



Length of canal covered in 1 min = $(1/60) \times 10$ km

Length of canal covered in 30 min (l) = $(30/60) \times 10 = 5$ km = 5000 m

We know that the canal is cuboidal in shape. So,

The volume of the canal = $l \times b \times h$

$$= 5000 \times 6 \times 1.5 \text{ m}^3$$

$$= 45000 \text{ m}^3$$

Now,

The volume of water in the canal = Volume of area irrigated

$$= \text{Area irrigated} \times \text{Height}$$

So, Area irrigated = 56.25 hectares

∴ The volume of the canal = $l \times b \times h = 45000$

$$= \text{Area irrigated} \times 8 \text{ cm}$$

$$45000 = \text{Area irrigated} \times (8/100) \text{ m}$$

Or, Area irrigated = $562500 \text{ m}^2 = 56.25$ hectares.

9. A farmer connects a pipe of internal diameter 20 cm from a canal into a cylindrical tank in her field, which is 10 m in diameter and 2 m deep. If water flows through the pipe at the rate of 3 km/h, in how much time will the tank be filled?

Solution:

Consider the following diagram-



$$\text{Radius } (r_1) \text{ of circular end of pipe} = \frac{20}{200} = 0.1 \text{ m}$$

$$\text{Area of cross-section} = \pi \times r_1^2 = \pi \times (0.1)^2 = 0.01\pi \text{ m}^2$$

$$\text{Speed of water} = 3 \text{ km/h} = \frac{3000}{60} = 50 \text{ metre/min}$$

$$\text{Volume of water that flows in 1 minute from pipe} = 50 \times 0.01\pi = 0.5\pi \text{ m}^3$$

The volume of water that flows in t minutes from pipe = $t \times 0.5\pi \text{ m}^3$



Radius (r_2) of circular end of cylindrical tank = $10/2 = 5$ m

Depth (h_2) of cylindrical tank = 2 m

Let the tank be filled completely in t minutes.

The volume of water filled in the tank in t minutes is equal to the volume of water flowed in t minutes from the pipe.

The volume of water that flows in t minutes from pipe = Volume of water in tank $t \times 0.5\pi = \pi \times r_2^2 \times h_2$

Or, $t = 100$ minutes

EXERCISE: 13.4

(PAGE NO: 257)

1. A drinking glass is in the shape of a frustum of a cone of height 14 cm. The diameters of its two circular ends are 4 cm and 2 cm. Find the capacity of the glass.

Solution:

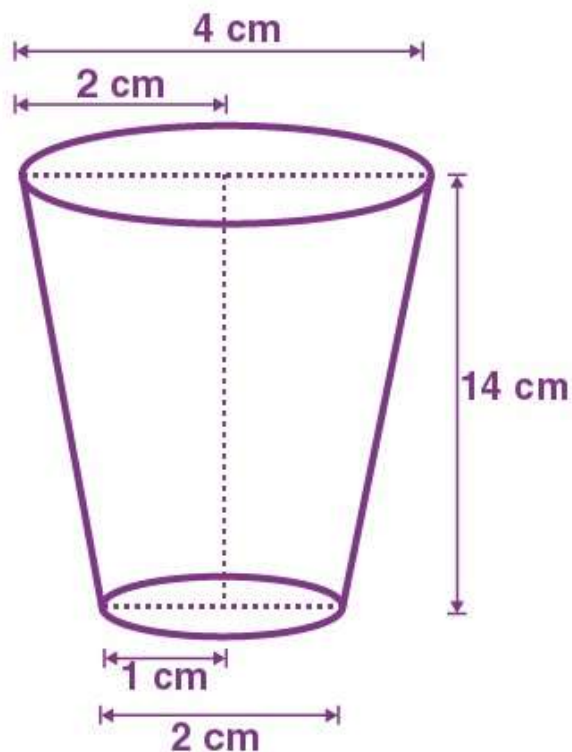

Radius (r_1) of the upper base = $4/2 = 2$ cm Radius

(r_2) of lower the base = $2/2 = 1$ cm

Height = 14 cm

Now, the capacity of glass = Volume of the frustum of the cone

So, Capacity of glass = $(\frac{1}{3}) \times \pi \times h(r_1^2 + r_2^2 + r_1 r_2) =$

$(\frac{1}{3}) \times \pi \times (14)(2^2 + 1^2 + (2)(1))$

\therefore The capacity of the glass = $102 \times (\frac{2}{3}) \text{ cm}^3$

2. The slant height of a frustum of a cone is 4 cm, and the perimeters (circumference) of its circular ends are 18 cm and 6 cm. Find the surface area of the frustum.

Solution:

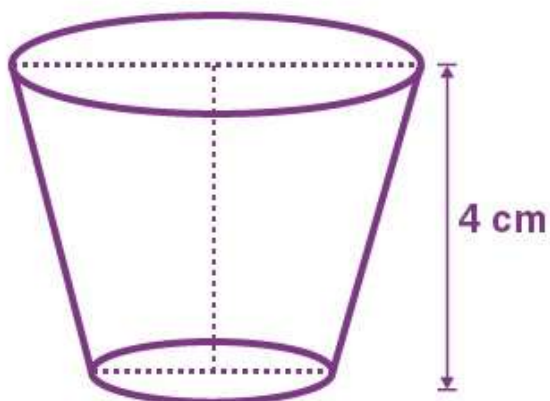

Given,

Slant height (l) = 4 cm

Circumference of upper circular end of the frustum = 18 cm

$$\therefore 2\pi r_1 = 18$$

$$\text{Or, } r_1 = 9/\pi$$

Similarly, the circumference of the lower end of the frustum = 6 cm

$$\therefore 2\pi r_2 = 6$$

$$\text{Or, } r_2 = 3/\pi$$

Now, the surface area of the frustum = $\pi(r_1+r_2) \times l$

$$= \pi(9/\pi+3/\pi) \times 4$$

$$= 12 \times 4 = 48 \text{ cm}^2$$

3. A fez, the cap used by the Turks, is shaped like the frustum of a cone (see Fig.). If its radius on the open side is 10 cm, the radius at the upper base is 4 cm, and its slant height is 15 cm, find the area of material used for making it.



Fig. 13.24

Solution:

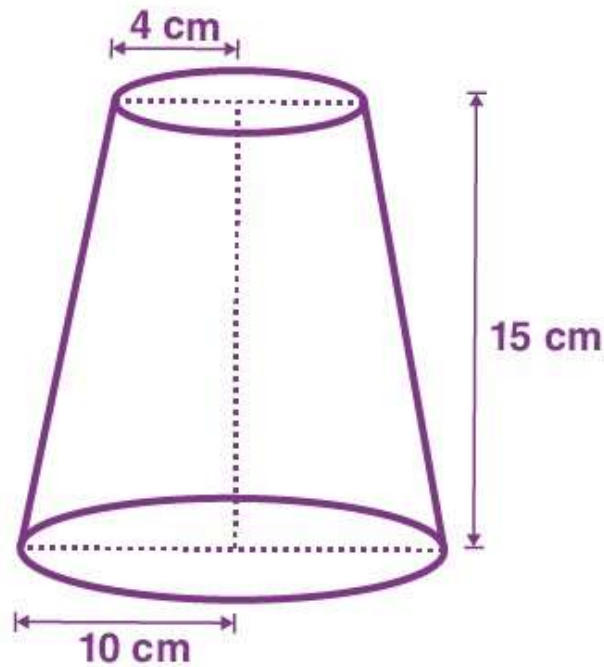

Given,

For the lower circular end, radius (r_1) = 10 cm

For the upper circular end, radius (r_2) = 4 cm

Slant height (l) of frustum = 15 cm

Now,

The area of material to be used for making the fez = CSA of frustum + Area of the upper circular end

CSA of frustum = $\pi(r_1+r_2) \times l$



$$= 210\pi$$

And, the Area of the upper circular end = πr_2^2

$$= 16\pi$$

The area of material to be used for making the fez = $210\pi + 16\pi = (226 \times 22)/7 = 710 \frac{2}{7}$

∴ The area of material used = $710 \frac{2}{7} \text{ cm}^2$

4. A container, opened from the top and made up of a metal sheet, is in the form of a frustum of a cone of height 16 cm with radii of its lower and upper ends as 8 cm and 20 cm, respectively. Find the cost of the milk which can completely fill the container at the rate of Rs. 20 per litre. Also, find the cost of the metal sheet used to make the container if it costs Rs. 8 per 100 cm^2 .

Solution:

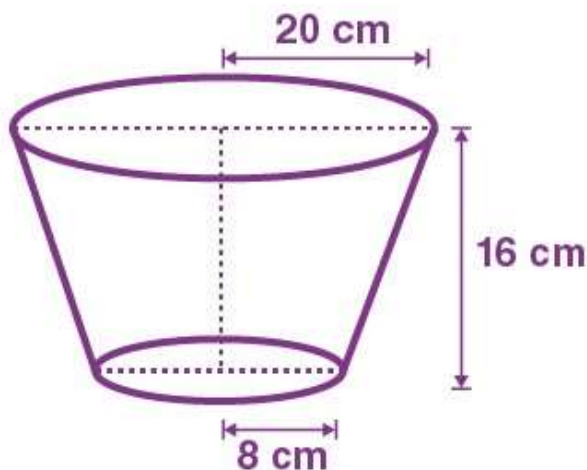

Given, $r_1 =$

20 cm, $r_2 = 8$

cm and $h =$

16 cm

∴ Volume of the frustum = $(\frac{1}{3}) \times \pi \times h (r_1^2 + r_2^2 + r_1 r_2)$

$$= \frac{1}{3} \times 3.14 \times 16 ((20)^2 + (8)^2 + (20)(8))$$

$$= \frac{1}{3} \times 3.14 \times 16 (400 + 64 + 160) = 10449.92 \text{ cm}^3 = 10.45 \text{ lit}$$

It is given that the rate of milk = Rs. 20/litre

So, the cost of milk = $20 \times$ volume of the frustum



$$= 20 \times 10.45$$

$$= \text{Rs. } 209$$

Now, the slant height will be

$$l = \sqrt{h^2 + (r_1 - r_2)^2} = \sqrt{16^2 + (20 - 8)^2} = \sqrt{16^2 + 12^2}$$

$$l = 20 \text{ cm}$$

So, CSA of the container = $\pi(r_1 + r_2) \times l$

$$= \frac{314}{100} (20 + 8) \times 20 \text{ cm}^2$$

$$= 1758.4 \text{ cm}^2$$

Hence, the total metal that would be required to make the container will be = $1758.4 + (\text{Area of the bottom circle})$

$$= 1758.4 + \pi r^2 = 1758.4 + \pi(8)^2$$

$$= 1758.4 + 201 = 1959.4 \text{ cm}^2$$

$$\therefore \text{Total cost of metal} = \text{Rs. } (8/100) \times 1959.4 = \text{Rs. } 157$$

5. A metallic right circular cone 20 cm high and whose vertical angle is 60° is cut into two parts at the middle of its height by a plane parallel to its base. If the frustum so obtained is drawn into a wire of diameter $1/16$ cm, find the length of the wire.

Solution:

The diagram will be as follows

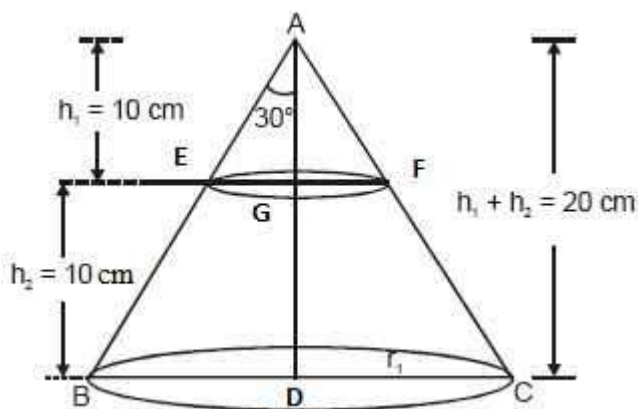

Consider AEG



$$\frac{EG}{AG} = \tan 30^\circ$$

$$EG = \frac{10}{\sqrt{3}} \text{ cm} = \frac{10\sqrt{3}}{3}$$

In $\triangle ABD$,

$$\frac{BD}{AD} = \tan 30^\circ$$

$$BD = \frac{20}{\sqrt{3}} = \frac{20\sqrt{3}}{3} \text{ cm}$$

Radius (r_1) of upper end of frustum = $(10\sqrt{3})/3$ cm

Radius (r_2) of lower end of container = $(20\sqrt{3})/3$ cm

Height (h) of container = 10 cm

Now,

Volume of the frustum = $(\frac{1}{3}) \times \pi \times h(r_1^2 + r_2^2 + r_1 r_2)$

$$= \frac{1}{3} \times \pi \times 10 \left[\left(\frac{10\sqrt{3}}{3} \right)^2 + \left(\frac{20\sqrt{3}}{3} \right)^2 + \frac{(10\sqrt{3})(20\sqrt{3})}{3 \times 3} \right]$$

Solving this, we get

Volume of the frustum = $22000/9$ cm³

The radius (r) of wire = $(1/16) \times (1/2) = 1/32$ cm

Now,

Let the length of the wire be “ l ”.

The volume of wire = Area of cross-section x Length

$$= (\pi r^2) \times l$$

$$= \pi (1/32)^2 \times l$$

Now, Volume of frustum = Volume of wire

$$22000/9 = (22/7) \times (1/32)^2 \times l$$

Solving this, we get, $l =$

7964.44 m

**EXERCISE: 13.5 (OPTIONAL)****(PAGE NO: 258)**

1. A copper wire, 3 mm in diameter, is wound about a cylinder whose length is 12 cm, and diameter 10 cm, so as to cover the curved surface of the cylinder. Find the length and mass of the wire, assuming the density of copper to be 8.88 g per cm^3 .

Solution:

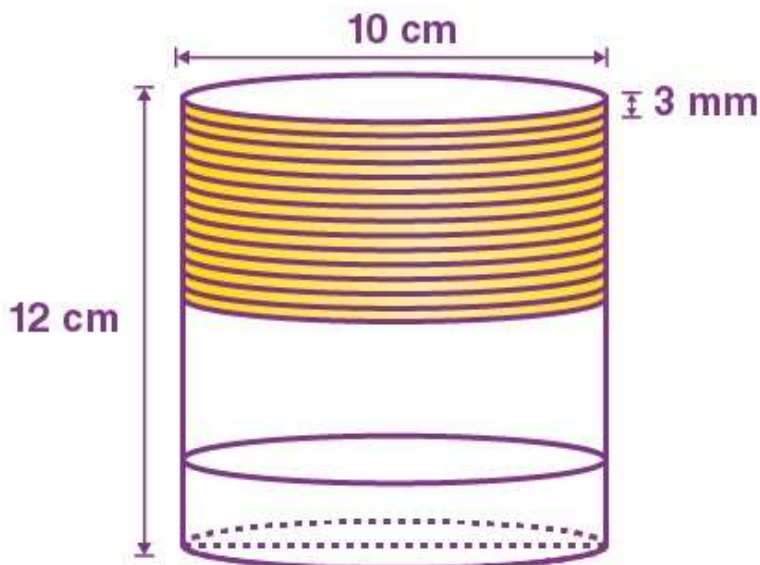

Given that,

Diameter of cylinder = 10 cm

So, the radius of the cylinder (r) = $10/2$ cm = 5 cm

\therefore Length of wire in completely one round = $2\pi r = 3.14 \times 5$ cm = 31.4 cm

It is given that diameter of wire = 3 mm = $3/10$ cm

\therefore The thickness of the cylinder covered in one round = $3/10$ m

Hence, the number of turns (rounds) of the wire to cover 12 cm will be

$$= \frac{12}{3/10} = 12 \times \frac{10}{3} = 40$$

Now, the length of wire required to cover the whole surface = length of wire required to complete 40 rounds

$$40 \times 31.4 \text{ cm} = 1256 \text{ cm}$$

Radius of the wire = $0.3/2 = 0.15$ cm



The volume of wire = Area of the cross-section of wire \times Length of wire

$$= \pi(0.15)^2 \times 1257.14$$

$$= 88.898 \text{ cm}^3$$

We know,

$$\text{Mass} = \text{Volume} \times \text{Density}$$

$$= 88.898 \times 8.88$$

$$= 789.41 \text{ gm}$$

2. A right triangle whose sides are 3 cm and 4 cm (other than the hypotenuse) is made to revolve about its hypotenuse. Find the volume and surface area of the double cone so formed. (Choose the value of π as found appropriate)

Solution:

Draw the diagram as follows:

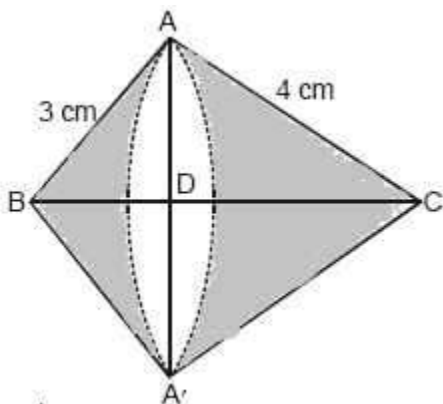

Let us consider the $\triangle ABA$

Here,

$$AS = 3 \text{ cm}, AC = 4 \text{ cm}$$

$$\text{So, Hypotenuse } BC = 5 \text{ cm}$$

We have got 2 cones on the same base AA' where the radius = DA or DA'

$$\text{Now, } AD/CA = AB/CB$$

By putting the value of CA , AB and CB , we get,

$$AD = 2/5 \text{ cm}$$

We also know,



$$DB/AB = AB/CB$$

$$\text{So, } DB = 9/5 \text{ cm}$$

$$\text{As, } CD = BC - DB,$$

$$CD = 16/5 \text{ cm}$$

Now, the volume of the double cone will be

$$= \left[\frac{1}{3} \pi \times \left(\frac{12}{5} \right)^2 \times \frac{9}{5} + \frac{1}{3} \pi \times \left(\frac{12}{5} \right)^2 \times \frac{16}{5} \right] \text{cm}^3$$

Solving this, we get

$$V = 30.14 \text{ cm}^3$$

The surface area of the double cone will be

$$= \left(\pi \times \frac{12}{5} \times 3 \right) + \left(\pi \times \frac{12}{5} \times 4 \right) \text{cm}^2 = \pi \times \frac{12}{5} [3 + 4] \text{cm}^2$$

$$= 52.75 \text{ cm}^2$$

3. A cistern, internally measuring 150 cm × 120 cm × 100 cm, has 129600 cm³ of water in it. Porous bricks are placed in the water until the cistern is full to the brim. Each brick absorbs one-seventeenth of its own volume of water. How many bricks can be put in without overflowing the water, each being 22.5 cm × 7.5 cm × 6.5 cm?

Solution:

Given that the dimension of the cistern = 150 × 120 × 110

So, volume = 1980000 cm³

Volume to be filled in cistern = 1980000 – 129600

= 1850400 cm³

Now, let the number of bricks placed to be “n”

So, the volume of n bricks will be = n × 22.5 × 7.5 × 6.5

Now, as each brick absorbs one-seventeenth of its volume, the volume will be

$$= n / (17) \times (22.5 \times 7.5 \times 6.5)$$

For the condition given in the question,

The volume of n bricks has to be equal to the volume absorbed by n bricks + the volume to be filled in the cistern



$$\text{Or, } n \times 22.5 \times 7.5 \times 6.5 = 1850400 + n(17) \times (22.5 \times 7.5 \times 6.5)$$

Solving this, we get $n = 1792.41$

4. In one fortnight of a given month, there was a rainfall of 10 cm in a river valley. If the area of the valley is 7280 km², show that the total rainfall was approximately equivalent to the addition to the normal water of three rivers, each 1072 km long, 75 m wide and 3 m deep.

Solution:

From the question, it is clear that

$$\text{Total volume of 3 rivers} = 3 \times [(\text{Surface area of a river}) \times \text{Depth}]$$

Given,

$$\text{Surface area of a river} = [1072 \times (75/1000)] \text{ km}$$

And,

$$\text{Depth} = (3/1000) \text{ km}$$

$$\text{Now, volume of 3 rivers} = 3 \times [1072 \times (75/1000)] \times (3/1000)$$

$$= 0.7236 \text{ km}^3$$

Now, the volume of rainfall = total surface area \times total height of rain

$$= 7280 \times \frac{10}{100 \times 1000} \text{ km}^3$$

$$= 0.7280 \text{ km}^3$$

For the total rainfall to be approximately equivalent to the addition to the normal water of three rivers, the volume of rainfall has to be equal to the volume of 3 rivers.

$$\text{But, } 0.7280 \text{ km}^3 = 0.7236 \text{ km}^3$$

So, the question statement is true.

5. An oil funnel made of a tin sheet consists of a 10 cm long cylindrical portion attached to a frustum of a cone. If the total height is 22 cm, the diameter of the cylindrical portion is 8 cm, and the diameter of the top of the funnel is 18 cm, find the area of the tin sheet required to make the funnel (see Fig.).

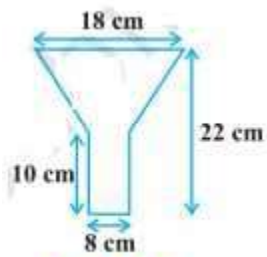

Fig. 13.25

Solution:

Given,

Diameter of the upper circular end of the frustum part = 18 cm

So, radius (r_1) = 9 cm

Now, the radius of the lower circular end of the frustum (r_2) will be equal to the radius of the circular end of the cylinder

So, $r_2 = 8/2 = 4$ cm

Now, height (h_1) of the frustum section = $22 - 10 = 12$ cm

And,

Height (h_2) of cylindrical section = 10 cm (given) Now,

the slant height will be-

$$l = \sqrt{(r_1 - r_2)^2 + h_1^2}$$

Or, $l = 13$ cm

Area of tin sheet required = CSA of frustum part + CSA of the cylindrical part

$$= \pi(r_1 + r_2)l + 2\pi r_2 h_2$$

Solving this, we get

Area of tin sheet required = $782 \frac{4}{7}$ cm²

6. Derive the formula for the curved surface area and total surface area of the frustum of a cone, given to you in Section 13.5, using the symbols as explained.

Solution:

Consider the diagram

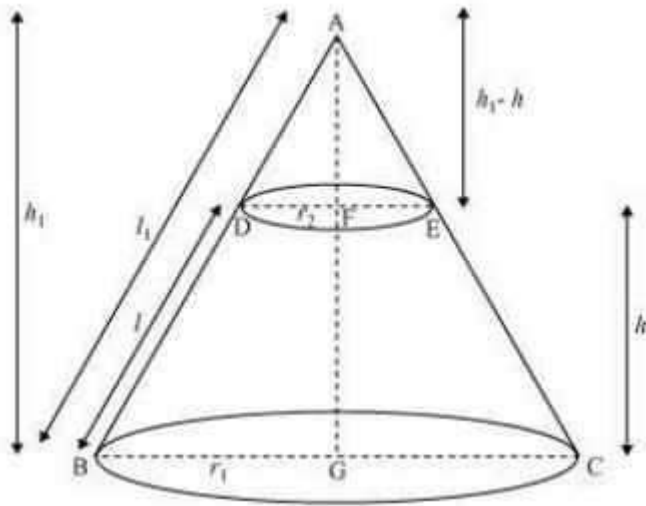

Let ABC be a cone. From the cone, the frustum DECB is cut by a plane parallel to its base. Here, r_1 and r_2 are the radii of the frustum ends of the cone, and h is the frustum height.

Now, consider the $\triangle ABG$ and $\triangle ADF$,

Here, $DF \parallel BG$

So, $\triangle ABG \sim \triangle ADF$

$$\frac{DF}{BG} = \frac{AF}{AG} = \frac{AD}{AB}$$
$$\frac{r_2}{r_1} = \frac{h_1 - h}{h_1} = \frac{l_1 - l}{l_1}$$
$$\frac{r_2}{r_1} = 1 - \frac{h}{h_1} = 1 - \frac{l}{l_1}$$
$$\frac{1 - l}{l_1} = \frac{r_2}{r_1}$$
$$\frac{l}{l_1} = 1 - \frac{r_2}{r_1} = \frac{r_1 - r_2}{r_1}$$

Now, by rearranging, we get



$$l_1 = \frac{r_1 l}{r_1 - r_2}$$

$$\begin{aligned}\text{CSA of frustum DECB} &= \text{CSA of cone ABC} - \text{CSA cone ADE} \\ &= \pi r_1 l_1 - \pi r_2 (l_1 - l) \\ &= \pi r_1 \left(\frac{l r_1}{r_1 - r_2} \right) - \pi r_2 \left[\frac{r_1 l}{r_1 - r_2} - l \right] \\ &= \frac{\pi r_1^2 l}{r_1 - r_2} - \pi r_2 \left(\frac{r_1 l - r_1 l + r_2 l}{r_1 - r_2} \right) \\ &= \frac{\pi r_1^2 l}{r_1 - r_2} - \frac{\pi r_2^2 l}{r_1 - r_2} \\ &= \pi l \left[\frac{r_1^2 - r_2^2}{r_1 - r_2} \right]\end{aligned}$$

$$\text{CSA of frustum} = \pi(r_1 + r_2)l$$

The total surface area of the frustum will be equal to the total CSA of the frustum + the area of the upper circular end + the area of the lower circular end

$$= \pi(r_1 + r_2)l + \pi r_2^2 + \pi r_1^2$$

$$\therefore \text{Surface area of frustum} = \pi[(r_1 + r_2)l + r_1^2 + r_2^2]$$

7. Derive the formula for the volume of the frustum of a cone.

Solution:

Consider the same diagram as the previous question.

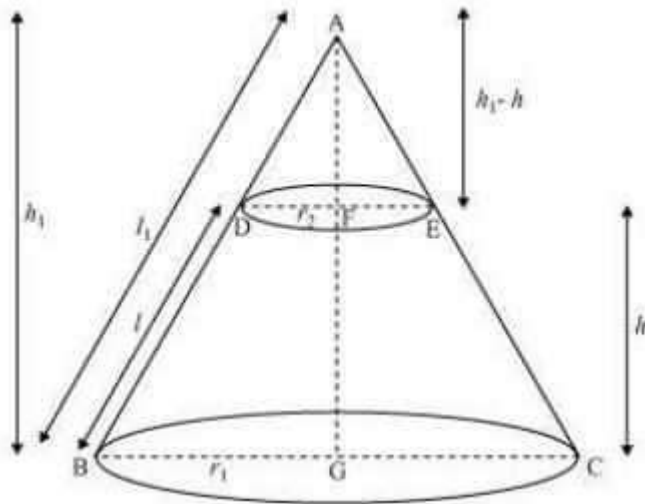

Now, approach the question in the same way as the previous one and prove that

$$\triangle ABG \sim \triangle ADF$$

Again,

$$\frac{DF}{BG} = \frac{AF}{AG} = \frac{AD}{AB}$$

$$\frac{r_2}{r_1} = \frac{h_1 - h}{h_1} = \frac{l_1 - l}{l_1}$$

Now, rearrange them in terms of h and h₁

$$\frac{r_2}{r_1} = 1 - \frac{h}{h_1} = 1 - \frac{l}{l_1}$$

$$1 - \frac{h}{h_1} = \frac{r_2}{r_1}$$

$$\frac{h}{h_1} = 1 - \frac{r_2}{r_1} = \frac{r_1 - r_2}{r_1}$$

$$\frac{h_1}{h} = \frac{r_1}{r_1 - r_2}$$

$$h_1 = \frac{r_1 h}{r_1 - r_2}$$

The total volume of the frustum of the cone will be = Volume of cone ABC – Volume of cone ADE

$$= \left(\frac{1}{3}\right)\pi r_1^2 h_1 - \left(\frac{1}{3}\right)\pi r_2^2 (h_1 - h)$$



$$= (\pi/3)[r_1^2 h_1 - r_2^2(h_1 - h)]$$

$$= \frac{\pi}{3} \left[r_1^2 \left(\frac{hr_1}{r_1 - r_2} \right) - r_2^2 \left(\frac{hr_1}{r_1 - r_2} - h \right) \right]$$

$$= \frac{\pi}{3} \left[\left(\frac{hr_1^3}{r_1 - r_2} \right) - r_2^2 \left(\frac{hr_1 - hr_1 + hr_2}{r_1 - r_2} \right) \right]$$

$$= \frac{\pi}{3} \left[\frac{hr_1^3}{r_1 - r_2} - \frac{hr_2^3}{r_1 - r_2} \right]$$

$$= \frac{\pi}{3} h \left[\frac{r_1^3 - r_2^3}{r_1 - r_2} \right]$$

$$= \frac{\pi}{3} h \left[\frac{(r_1 - r_2)(r_1^2 + r_1 r_2 + r_2^2)}{r_1 - r_2} \right]$$

Now, solving this, we get

$$\therefore \text{The volume of frustum of the cone} = \left(\frac{1}{3}\right)\pi h(r_1^2 + r_2^2 + r_1 r_2)$$